

#BIGPOWERBLOCK

ÉCLIPSE 3

Put your creativity to work! Sometimes you need to do just that when preparing large rigging jobs, and now you can customise your Eclipse pulley for those challenges. Our team put their noses to the grindstone so that you can have equipment reflecting the strength and inspiration you exude. And it's engraved right in our workshop!

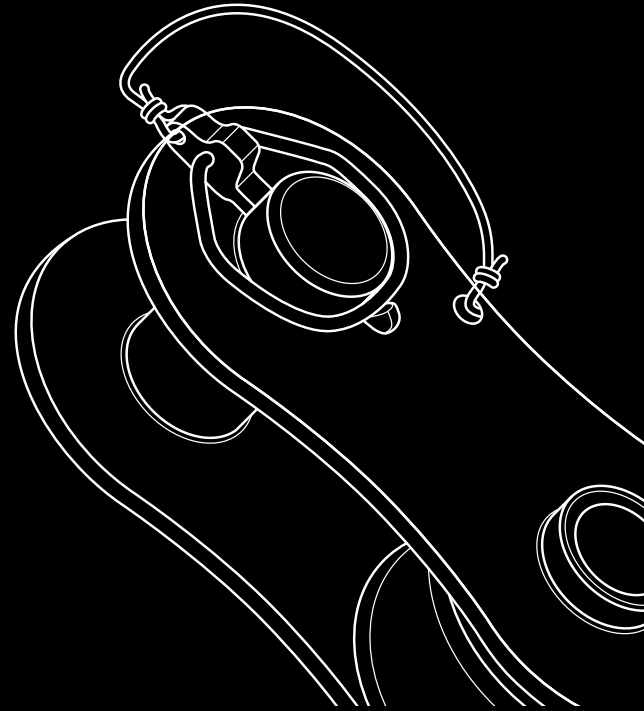

RIGGING BLOCK



DESCRIPTION

It is extremely practical thanks to its movable upper axle and rotating cheek plates that permit quick release of the attaching sling and rope.

It is locked with a safety lynch pin (against unwanted opening) that can't be lost thanks to its attachment string.

The sides of the cheek plates and the sheave are rounded to prevent damage to ropes during incorrect use. The sheave (Ø 90 mm - 3.54 in) contains a deep groove that can hold up ropes up to Ø 18 mm.

Aluminium sheave:

- highly resistant to pulling and shocks
- excellent resistance over time and to chemical agents

- low friction coefficient
- a very high resistance to abrasion

TECHNICAL INFORMATION

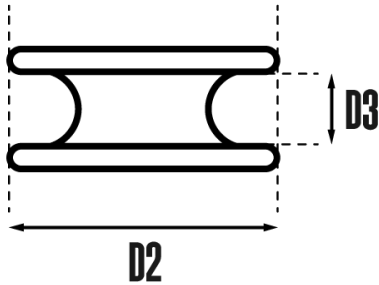
Machinery Directive	2006/42/CE
	
Diameter(s)	Exterior: 93 mm (D2) Groove: 19 mm (D3)
Max. rope diameter (D3)	ø18 mm
Weight	1,020 g (2.2 lb)
MBS	150 kN - WLL, coef. 5: 30 KN

REFERENCES

FTC/PE3-R-ALU Version - Standard

FTC/PE3-GR Version - Customised

DOCUMENT

Instructions

DECLARATION OF CONFORMITY

